

MOV Backseat Relay for DC Motors User's Manual

1 INTRODUCTION

This device is used to backseat motor operated valves (MOV) to stop packing leaks while minimizing stress on the valve. It is connected at the motor control center to bypass the open limit switch. Clamp-on current sensors are used to measure current to the valve motor. By sensing an increase in current, it detects the valve at the backseat and opens a contact to remove power from the valve motor.

The Model 201602-DC is configured for DC valve motors and may also be used with AC motors using an AC/DC probe on a single phase.

For MOV Backseat Relay for 3 phase AC motors, refer to TM201602-AC.

This manual is applicable to firmware version 3.1 through 3.1.1.



2 SPECIFICATIONS

Inputs:	-1 to +1 Volts DC, corresponding to 100 Amps motor current using 10 mV/A AC/DC current probes. Auto scaling is used to measure current in ranges of approximately 2, 15, and greater amps.
Input Impedance:	1 megohm, with TVS overvoltage protection
Accuracy:	5% , 10 bit (1/1024) resolution
Output:	MOSFET opto-isolated solid state relays rated for 400 volts AC/DC, 2 amps continuous duty. Dual MOSFET relays are used in series for the output contact, along with an independent permit logic circuit controlled by the panel buttons, to reduce the possibility of a single failure keeping the motor running.
Logging:	Text file to Micro SD memory card (up to 32 GB)
Connectors:	4mm safety banana jacks
Response Time:	< 9 milliseconds (1/2 cycle) trip current sensing
Display:	2 lines x 20 characters LCD, backlit
Indications:	LEDs, green (contact open) and red (contact closed)
Controls:	POWER turn on or turn off the unit OPERATE MOV close contact and begin a test sequence STOP stop a test sequence and open contact SETUP view and step through settings [+], [-] change a setting
Power:	6 volts DC from four AA alkaline (supplied) or lithium batteries, good for up to 16 hours of operation.
Auto Shutoff:	After 30 minutes with no key press
Size:	195mm x 101mm x 44mm
Weight:	0.5 kg

3 CURRENT PROBES

The following probe made by AEMC Instruments has been evaluated as suitable for this application. Other models and manufacturers may also be used.

AC/DC clip-on current probes use Hall Effect to measure DC and a transformer to measure AC. Typical sensitivity is 10 mV/A. Examples are the AEMC SL206 and Fluke 80I-110S. The backseat relay can be set for probe ranges of 1 mV/A, 10 mV/A, 100 mV/A and 1 V/A. The DC version of the backseat relay differs from the AC version by having a 1 megohm input impedance so as not to load the probe beyond its specifications.



4 DESCRIPTION OF OPERATION

- 4.1 The purpose of the relay is to sense the increased current drawn by the valve motor when the load increases as the valve backseats against the packing. The relay contact is connected into the Motor Control Center (MCC) and is closed to start operation of the motor. Upon sensing increased current, the relay contact is opened, thereby removing power from the valve motor.
- 4.2 Probe inputs are sampled at a rate of 3600 samples per second. A moving RMS calculation is performed on the most recent 60 samples (1 cycle). The probe selection adds a gain factor to calculate amperage. Current readings for each phase are added together to obtain the displayed motor current.
- 4.3 The probe may be connected to any phase jacks, but the phase must be specified in a menu selection. This is because the DC option has high impedance inputs that are more susceptible to noise pickup if not terminated. By selecting the input phase, the other two phase input signals are ignored.
- 4.4 When the relay contact is closed, there will be a current inrush surge as the motor starts up. An inrush delay is specified to prevent tripping during this surge.
- 4.5 The input amplifiers have three ranges. The gain is reduced automatically to keep the inrush surge in range of the analog to digital converter. This improves resolution for smaller motors.
- 4.6 At the end of the inrush delay, current is measured and a trip setpoint is established as a percentage of this current. The motor will continue to run at a constant current until the backseat is reached and motor current increases. When the current increases above the setpoint, the relay opens to stop the motor.
- 4.7 A second maximum current setpoint is specified as a safety backup in case the valve is already against the backseat; i.e., motor rotor stalled. It is established as a percentage of the maximum current detected during the inrush surge. If the current exceeds this setpoint after the inrush delay, the relay opens to stop the motor.
- 4.8 A failed probe trip is implemented with two tests.
 - At the end of the delay state, a probe failure trip setpoint will be established at 20% of the operating current. If the current drops below this setpoint during the operate state, the failed probe trip will occur.
 - If inrush current is not detected within 50 milliseconds of relay contact closure, a failed trip will occur. This test will be disabled if the Motor Start From option is set to B- Control Panel
- 4.9 Since all setpoints are expressed as percentages, accurate calibration of the relay or probes is not relevant to trip functioning.

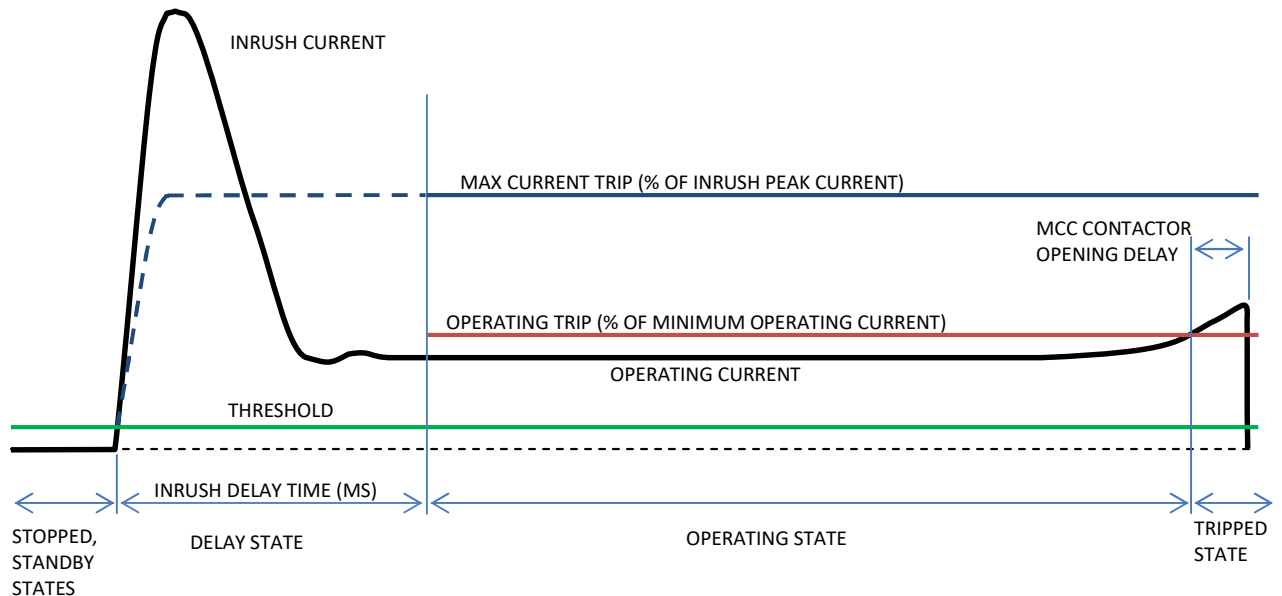

Figure 1: Typical Test Sequence

- 4.10 Figure 1 shows a hypothetical current trace (not to scale) for a run. The relay progresses through various states according to the sensed current.
- 4.11 In the STOPPED state, the relay contact is open and the current sensed must be zero. During this time, a self-calibration of the zero current level is performed for use in later calculations. If current or excessive noise is detected, an error message will display.
- 4.12 When OPERATE MOV is pressed, the STANDBY state is entered. The relay contact is closed and the inputs are compared to a threshold setting. When input exceeds threshold, the DELAY state is entered.
- 4.13 The maximum current trip setpoint is initialized and continuously recalculated as the specified percentage of the measured current during the delay. It begins lower than the current during the delay state and follows the current, but only increasing.
- 4.14 The operating and maximum current trips are not enabled during the delay state.
- 4.15 OPERATING state is entered when the inrush delay time ends.
- 4.16 The initial operating current trip setpoint is determined by multiplying the measured current at start of operating state by the specified setpoint percentage.
- 4.17 The actual inrush surge time is determined by scanning the readings taken during the delay and determining the time at which the current dropped to a level close to the operating current.
- 4.18 The operating current trip setpoint will continue to follow the current down, but not up.
- 4.19 In the operating state the operating trip and maximum trip will be enabled.
- 4.20 If the motor is stalled or if the delay is specified too small, current may be above the maximum current setpoint when operating state is entered. The MAX CURRENT TRIP will result.
- 4.21 When the valve reaches the backseat, current will increase until the operating trip setpoint is reached. The OPER CURRENT TRIP will occur.

- 4.22 After the relay contact opens, current will continue to increase until the motor controller mechanical contacts have physically opened. This is normally a few milliseconds. This is recorded as post trip current.
- 4.23 When any trip occurs, the relay contact opens and the display shows *Review Results* and the cause of trip. The [+] or [-] buttons may be pressed to show recorded readings of inrush peak current, inrush time, operating current, run time, trip current, and post trip current. Data points at 1 millisecond intervals are also shown for the first two seconds and last two seconds of the run. These results and data points are retained until the next run or until the device is turned off.
- 4.24 If a memory card is inserted prior to start of the run, data points and results will be logged to file (Section 7).

5 OPERATING PROCEDURE

- 5.1 If the batteries were replaced and an SD card will be used to record results, turn on the device and step through the SETUP options to set the date and time.
- 5.2 If a recorded log of the test and results is desired, insert a Micro-SD memory card into the small slot on the right side of the case, near the [+] button. Insert with SD card contacts facing front.
- 5.3 Connect test leads from the yellow relay contact jacks to parallel with the limit switches in the motor control cabinet. Typical connection points are shown in Figure 2. Option A gives full control to the relay. With option B, the relay just bypasses the limit switches.

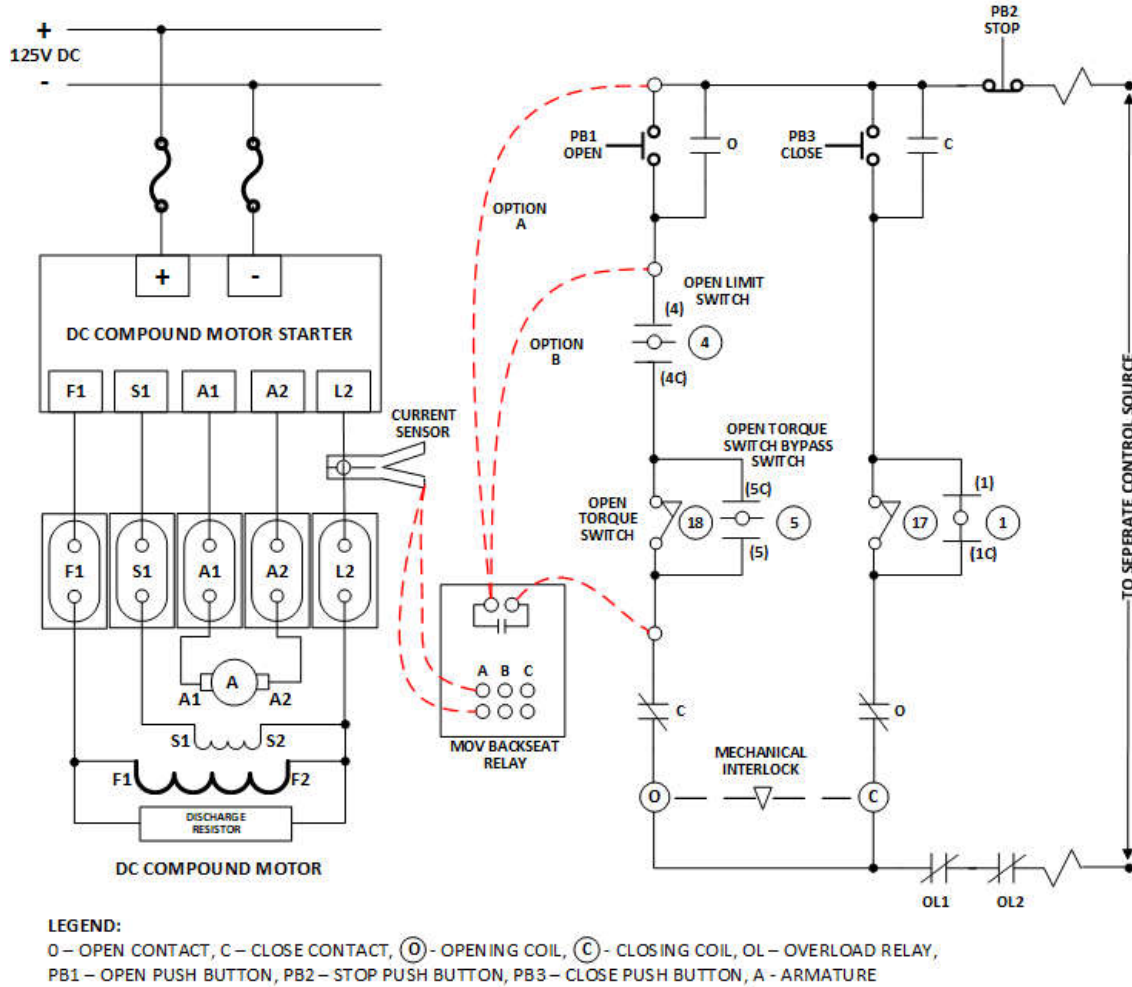



Figure 2: Typical Connection Diagram for DC

- 5.4 If an independent secondary protective device is desired, its contact may be wired in series with the relay.
- 5.5 Press the power button  to turn on device. After the startup identification, the display will show *PREREQ: Press SETUP to verify settings.*
- 5.6 Repeatedly press SETUP to cycle through the settings. Press the [+] or [-] button to make changes.
 - Operating Trip - the operating trip setpoint is set as a percent of the operating current, with 100% being the minimum steady state motor operating current. Thus, a 150% setting for a 10 amp current will give a trip at 15 amps. Default value is 110%. Range is 101% to 500%.

- Inrush Delay Time - this time, in milliseconds, is the delay to allow for the inrush current spike to settle out before determining the operating current. Recommended is at least 50 ms longer than the measured inrush time. Default is 250ms. Range is 40 to 2000 milliseconds.
- Max Current Trip – the maximum trip setpoint is set as a percentage of the inrush current during the delay. It is set to less than 100% with 100% being the peak inrush current detected during the delay. Default is 50%. Range is 10% to 95%.
- AC/DC on Probe Jacks – Select the phase jacks to which the probe is connected. The selection MUST match the phase jacks in use.

WARNING: Probe connected to wrong phase jacks will not detect motor current. MOTOR WILL BE UNPROTECTED. (Failed Probe Trip should detect this if Motor Start From is set to A-This Device, but NOT if B-Control Panel.)

- AC/DC Probe Gain – Standard probe is 10 mV/A. If another probe sensitivity is used, select here. Options are 1 mV/A, 10 mV/A, 100 mV/A, and 1 V/A.
- Phase A[B,C] Probe Zero Adjust to 0 – AC/DC probes generally have a zero adjust knob on the probe. Turn on the probe and adjust the probe zero knob to obtain a reading of 0 (-5 to +5).
- Motor Start From – Select the connection option as described in Figure 2. When B-Control Panel is selected, the probe failure detection at the start of run will be disabled.
- Year, Month, Day, Hour, Minute – update if not previously set, may be ignored if there will be no logging to SD memory card.

5.7 (Optional) Review and select advanced menu items per Section 6.

5.8 After the setup pages have been reviewed, you will enter the STOPPED state.

5.9 If the battery icon is flashing to indicate the batteries are nearly discharged, replace the batteries and restart procedure.

5.10 If *Error Current/Noise* is displaying, this could be because

- The probes are detecting current
- DC probe has not been zeroed
- DC probe is not connected
- DC probe is connected to the wrong phase
- High electrical noise in area. Try increasing noise filter.

5.11 Press OPERATE MOV to start the run and close the relay contacts. The red LED will come on.

- If an SD memory card is inserted, there will be a notice and momentary delay (the delay gets longer with many files on the SD) while a new log file is opened.
- After the file is opened (if applicable), the red LED will come on and the relay contact will close to start the MOV.
- STOP may be pressed at any time to halt the test and open the relay contact.

5.12 If connection option B is used, initiate valve operation using the control panel OPEN switch.

5.13 If control circuit power is being supplied by a secondary device, initiate opening of the valve from this secondary device.

5.14 Display may show STANDBY until current is detected, then DELAY and then OPERATING.

- 5.15 When the motor current reaches a trip condition, the relay contact will open and the display will show *Review Results (+,-)* and the cause of trip:
- OPER CURRENT TRIP will occur when current exceeds the operating trip setpoint.
 - MAX CURRENT TRIP will occur if current exceeds the maximum trip, possibly caused by valve already against backseat or insufficient inrush delay time.
 - FAILED PROBE TRIP will occur if the probe became disconnected during the operate phase or if no current was detected at motor start from this device (Figure 2 option A).
 - MANUAL STOP if you pressed the STOP button to end run.
- 5.16 With *Review Results (+,-)* displayed, press [+] or [-] to review various measurements taken during the test. These are useful for establishing setup values for a valve without having to log to an SD memory card.
- Cause of trip
 - Inrush peak current
 - Inrush time (peak width)
 - Operating current
 - Run time (inrush + operating)
 - Trip current
 - Post trip current (maximum current following motor contactor delay)
 - Log file name (if logging to SD card)
 - Data points, at 1 millisecond intervals, showing time (ms), current, and state (delay, operating, or tripped). Up to 2000 points at the start of the run (2 seconds worth) and up to 2000 additional points at the end of the run will be available. Hold down the [+] or [-] key to accelerate the scan of points.
- 5.17 The run results will be retained until the relay is turned off or until another run is made. Review Results will now be available when stepping through the SETUP menus.
- 5.18 Press STOP to reset to the home state.
- 5.19 The SD memory card may be removed to transfer the log file to a computer for analysis.

6 SETUP MENUS

Two levels of setup menu are provided, standard and advanced. At power-up when the PREREQ screen is shown, the standard menu is enabled. At this time, you may press the [+] and [-] keys to change to advanced, or leave them alone to remain in standard. When in the STOPPED state, you may also press the keys to change menu level. If the wrong number of key presses is made, press STOP to reset the key counts and then try again.

Key codes

- Advanced menu: Press [+] exactly one time, press [-] exactly three times
- Standard menu: Press [+] exactly one time, press [-] exactly one time

The standard menu items are described in Step 5.6. The advanced menu includes those items plus these additional items:

- Noise Filter - This numerical value defines a noise filter applied to the calculated RMS current. It computes a running average, with older readings fading in importance. A larger value will give better noise filtering at the expense of slower response. Default value is 1 (no filtering). Range is 1 to 50.
- Threshold – The number of ADC Units (analog/digital converter decimal counts above background) at which the inrush surge is detected to begin the DELAY state. An input exceeding this during STOPPED will give an error message indicating current or noise is present on the input. Default value is 40 with 10 to 200 allowed. It should not need to be changed unless there is a high level of background electrical noise. 40 corresponds to approximately 0.8 amps with a 1 mA/A probe.
- Log File Contents – *Standard* setting will log the test setup, results, and current and state at one millisecond intervals. *Diagnostic* setting provides additional details that can be used by the factory for troubleshooting. These details are probably not meaningful to the user. Default value is *Standard*.
- Line Frequency – Select AC line frequency, 60 or 50 Hz, based on location. This establishes the sampling rate to acquire 30 samples in ½ cycle. Default is 60 Hz.
- Year, Month, Day, Hour, Minute – Use to set the internal clock/calendar that identifies the log files with the date and time of the test. These settings will also appear in standard menu if the clock has not been set following battery replacement. To save the updated time/date, you must step SETUP all the way through Minute.
- Restore Defaults? – This item only appears in the advanced menu if any item in the standard or advanced menu, other than line frequency or the clock/calendar, differs from the default value. Press [+] to restore or [-], SETUP, or STOP to keep your existing settings.

For both the normal and advanced settings, any changes except clock will be stored in non-volatile memory and retained when power is turned off or batteries removed. Battery removal will require clock reset. Run results data are not saved.

7 LOG FILE

Data logging of MOV runs is recorded to a Micro SD card. The card is inserted into a small slot on the right side of the case. Orient the card with contacts towards the front. After insertion, a portion of the card will extend about ¼” outside the case. Remove by gripping and pulling.

When OPERATE MOV is pressed to start a test, a new log file will be opened. The file name will contain the serial number and date/time of the test. For example,

```
MOV Backseat 036 Log 2022-02-21_0908.txt
```

Contents start with an identification of relay and date/time, followed by various settings. Next, current readings are recorded from the start of the inrush current until current drops after the contact is opened. Finally, results are recorded.

```
DC MOV Backseat Relay S/N 036
02/21/2022 09:08:04
Firmware Version 3.1
Operating Trip Setting = 120 %
Inrush Delay Time Setting = 150 ms
Max Current Trip Setting = 50 %
Input = DC (or AC) on Phase A
Probe Gain = 10 mV/A
Motor Start From = This Device
Noise Filter = 1
Threshold = 40 ADC Units
Line Frequency = 60 Hz
```

```
time(ms)    amps    state
-----
```

0	2.14	Delay
1	9.92	Delay
2	20.10	Delay
3	29.94	Delay
4	39.94	Delay
5	49.94	Delay
6	49.94	Delay
7	49.94	Delay
8	48.02	Delay
9	49.62	Delay
10	52.32	Delay
11	48.02	Delay
12	46.29	Delay
13	46.29	Delay
14	44.75	Delay
15	43.02	Delay
16	41.48	Delay
17	39.56	Delay
18	38.02	Delay
.		
.		
.		
3088	5.83	Operate
3089	5.87	Operate
3090	5.91	Operate
3091	5.95	Operate
3091	5.99	Tripped
3092	5.99	Tripped
3093	6.04	Tripped
3094	6.12	Tripped
3095	6.16	Tripped
3096	6.20	Tripped
3097	6.24	Tripped
3098	5.83	Tripped
3099	5.37	Tripped
3100	5.00	Tripped
3101	4.46	Tripped
3102	4.01	Tripped
3103	3.30	Tripped
3104	2.35	Tripped
3105	1.19	Tripped
3105	1.19	Tripped

Operating Current Trip

Inrush Peak Current = 52.3A
 Inrush Time = 29 ms
 Operating Current = 4.97A
 Trip Current = 6.00A
 Post Trip Current = 6.25A
 Run Time to Trip = 3.091 sec

The logged current readings are tab delineated, making the file suitable to opening in Excel for plotting and analysis.

No provisions are made for SD card formatting, file renaming, or file deletion. This must be done on an external computer. Card format is FAT32 and cards up to 32GB can be used. Micro-SD to USB adapters are commercially available if needed.

8 TROUBLESHOOTING

A clean DC reading is required for proper operation.

The operating current trip is proportional to the minimum current measured during the valve stroke. If shaft friction varies the current, this could affect the trip point.

9 MAINTENANCE

Calibration of the device may be performed but is not required. Trip setpoints are specified as a percentage of current and calibration of current readout has no effect on the backseat trip functionality. Refer to functional test and calibration procedure TP201602-01.

A battery icon displays on the STOPPED screen. *Replace Batteries* will display when battery drops below 4.3 volts. No operations are possible under low battery condition.

To replace batteries, remove panel at top rear of case. For long term storage, batteries should be removed to prevent damage from alkaline battery leakage.

For version information, including user's manual, functional test/calibration procedure, and download of the latest firmware version, see <http://campcreekttech.com/mov.html>.

Firmware on serial numbers 10 and later may be easily updated in the field using this procedure. For earlier serial numbers, contact Camp Creek Technologies for update.

NOTE: Calibration is not lost when firmware is updated

- 9.1 Download and unzip the update file. It will contain these instructions and an image.hex file.
- 9.2 Copy the image.hex file to a micro-SD card. The card used for logging may be used for this purpose.
- 9.3 Turn relay off.
- 9.4 Insert SD card into the slot on the side of the relay, contact side facing front.
- 9.5 Press the [-] key. While holding it down, press the power key.
- 9.6 The screen will show "Bootloader v1.1, Press SETUP to pgm."
- 9.7 The [-] key may be released once the bootloader screen displays.
- 9.8 If you wish to cancel the update, press the STOP or power key.
- 9.9 Press SETUP. The screen will show *Erasing* for about 3 seconds followed by *Programming* for about 3 seconds.
- 9.10 Once complete, the normal relay startup screen will appear, identifying the version number.
- 9.11 The SD card may now be removed.

10 CONTACT INFORMATION

Camp Creek Technologies, Inc
619 Camp Creek Rd
Iron Station, NC 28080

support@campcreektech.com

(704) 748-2353

11 WARRANTY

Camp Creek Technologies warrants that the product is free from defects in materials and workmanship for a period of one year from date of purchase. If product proves defective during this warranty period, Camp Creek Technologies, at its option, will either repair the defective product without charge for parts or labor, or will provide a replacement in exchange for the defective product.

Revisions

Rev 0, 12/5/2021

New manual for DC MOVs derived from TM201602-AC rev 10
Applies to firmware version 3.0

Rev 1, 3/11/2022

Updated connection diagram
Firmware Version 3.1 changes
- Added probe failure trip

Rev 2, 6/7/2022

Firmware Version 3.1.1 changes
- Update RMS calculation to full cycle instead of 1/2. This reduces 60 Hz AC ripple and glitches in logged data.